

# Corporate Reporting (UK) (P2) September 2017 to June 2018

This syllabus and study guide is designed to help with planning study and to provide detailed information on what could be assessed in any examination session.

## THE STRUCTURE OF THE SYLLABUS AND STUDY GUIDE

### Relational diagram of paper with other papers

This diagram shows direct and indirect links between this paper and other papers preceding or following it. Some papers are directly underpinned by other papers such as Advanced Performance Management by Performance Management. These links are shown as solid line arrows. Other papers only have indirect relationships with each other such as links existing between the accounting and auditing papers. The links between these are shown as dotted line arrows. This diagram indicates where you are expected to have underpinning knowledge and where it would be useful to review previous learning before undertaking study.

### Overall aim of the syllabus

This explains briefly the overall objective of the paper and indicates in the broadest sense the capabilities to be developed within the paper.

### Main capabilities

This paper's aim is broken down into several main capabilities which divide the syllabus and study guide into discrete sections.

### Relational diagram of the main capabilities

This diagram illustrates the flows and links between the main capabilities (sections) of the syllabus and should be used as an aid to planning teaching and learning in a structured way.

### Syllabus rationale

This is a narrative explaining how the syllabus is structured and how the main capabilities are linked. The rationale also explains in further detail what the examination intends to assess and why.

### Detailed syllabus

This shows the breakdown of the main capabilities (sections) of the syllabus into subject areas. This is the blueprint for the detailed study guide.

### Approach to examining the syllabus

This section briefly explains the structure of the examination and how it is assessed.

### Study Guide

This is the main document that students, learning and content providers should use as the basis of their studies, instruction and materials. Examinations will be based on the detail of the study guide which comprehensively identifies what could be assessed in any examination session. The study guide is a precise reflection and breakdown of the syllabus. It is divided into sections based on the main capabilities identified in the syllabus. These sections are divided into subject areas which relate to the sub-capabilities included in the detailed syllabus. Subject areas are broken down into sub-headings which describe the detailed outcomes that could be assessed in examinations. These outcomes are described using verbs indicating what exams may require students to demonstrate, and the broad intellectual level at which these may need to be demonstrated (\*see intellectual levels below).

### INTELLECTUAL LEVELS

The syllabus is designed to progressively broaden and deepen the knowledge, skills and professional values demonstrated by the student on their way through the qualification.

The specific capabilities within the detailed syllabuses and study guides are assessed at one of three intellectual or cognitive levels:

Level 1: Knowledge and comprehension

Level 2: Application and analysis  
Level 3: Synthesis and evaluation

Very broadly, these intellectual levels relate to the three cognitive levels at which the Knowledge module, the Skills module and the Professional level are assessed.

Each subject area in the detailed study guide included in this document is given a 1, 2, or 3 superscript, denoting intellectual level, marked at the end of each relevant line. This gives an indication of the intellectual depth at which an area could be assessed within the examination. However, while level 1 broadly equates with the Knowledge module, level 2 equates to the Skills module and level 3 to the Professional level, some lower level skills can continue to be assessed as the student progresses through each module and level. This reflects that at each stage of study there will be a requirement to broaden, as well as deepen capabilities. It is also possible that occasionally some higher level capabilities may be assessed at lower levels.

## LEARNING HOURS AND EDUCATION RECOGNITION

The ACCA qualification does not prescribe or recommend any particular number of learning hours for examinations because study and learning patterns and styles vary greatly between people and organisations. This also recognises the wide diversity of personal, professional and educational circumstances in which ACCA students find themselves.

As a member of the International Federation of Accountants, ACCA seeks to enhance the education recognition of its qualification on both national and international education frameworks, and with educational authorities and partners globally. In doing so, ACCA aims to ensure that its qualifications are recognized and valued by governments, regulatory authorities and employers across all sectors. To this end, ACCA qualifications are currently recognized on the education frameworks in several countries. Please refer to your national education framework regulator for further information.

Each syllabus contains between 23 and 35 main subject area headings depending on the nature of

the subject and how these areas have been broken down.

## GUIDE TO EXAM STRUCTURE

The structure of examinations varies within and between modules and levels.

The Fundamentals level examinations contain 100% compulsory questions to encourage candidates to study across the breadth of each syllabus.

The Knowledge module is assessed by equivalent two-hour paper based and computer based examinations.

The *Corporate and Business Law* (F4) paper is a two- hour objective test examination which is also available as a computer based exams for English and Global variants, as well as paper based for all variants.

The skills module examinations F5-F9 contain a mix of objectives and longer type questions with a duration of three hours for 100 marks.\* These are available as computer-based and paper-based exams. In the computer-based exams there may be instances where we have extra content for the purposes of ongoing quality assurance and security.

*\* For paper-based exams there is an extra 15 minutes to reflect the manual effort required.*

The Professional level papers are all of three hours 15 minutes duration and, all contain two sections. Section A is compulsory, but there will be some choice offered in Section B.

ACCA has removed the restriction relating to reading and planning time, so that while the time considered necessary to complete these exams remains at 3 hours, candidates may use the additional 15 minutes as they choose. ACCA encourages students to take time to read questions carefully and to plan answers but once the exam time has started, there are no additional restrictions as to when candidates may start writing in their answer books.

Time should be taken to ensure that all the information and exam requirements are properly read and understood.

The Essentials module papers all have a Section A containing a major case study question with all requirements totalling 50 marks relating to this case. Section B gives students a choice of two from three 25 mark questions.

Section A of both the P4 and P5 Options papers contain one 50 mark compulsory question, and Section B will offer a choice of two from three questions each worth 25 marks each.

Section A of each of the P6 and P7 Options papers contains 60 compulsory marks from two questions; question 1 attracting 35 marks, and question 2 attracting 25 marks. Section B of both these Options papers will offer a choice of two from three questions, with each question attracting 20 marks.

All Professional level exams contain four professional marks.

The pass mark for all ACCA Qualification examination papers is 50%.

## GUIDE TO EXAMINATION ASSESSMENT

ACCA reserves the right to examine anything contained within the study guide at any examination session. This includes knowledge, techniques, principles, theories, and concepts as specified.

For the financial accounting, audit and assurance, law and tax papers except where indicated otherwise, ACCA will publish *examinable documents* once a year to indicate exactly what regulations and legislation could potentially be assessed within identified examination sessions..

For paper based examinations regulation *issued* or legislation *passed* on or before 31<sup>st</sup> August annually, will be examinable from 1<sup>st</sup> September of the following year to 31<sup>st</sup> August of the year after that. Please refer to the examinable documents for the paper (where relevant) for further information.

Regulation issued or legislation passed in accordance with the above dates may be examinable even if the *effective* date is in the future.

The term issued or passed relates to when regulation or legislation has been formally approved.

The term effective relates to when regulation or legislation must be applied to an entity transactions and business practices.

The study guide offers more detailed guidance on the depth and level at which the examinable documents will be examined. The study guide should therefore be read in conjunction with the examinable documents list.

# Syllabus

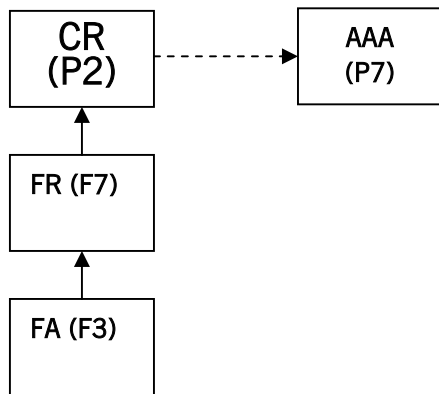

## AIM

To apply knowledge, skills and exercise professional judgement in the application and evaluation of financial reporting principles and practices in a range of business contexts and situations.

## MAIN CAPABILITIES

On successful completion of this paper candidates should be able to:

- A** Discuss the professional and ethical duties of the accountant
- B** Evaluate the financial reporting framework
- C** Advise on and report the financial performance of entities
- D** Prepare the financial statements of groups of entities in accordance with relevant accounting standards
- E** Explain reporting issues relating to specialised entities
- F** Discuss the implications of changes in accounting regulation on financial reporting
- G** Appraise the financial performance and position of entities
- H** Evaluate current developments

## RELATIONAL DIAGRAM OF MAIN CAPABILITIES

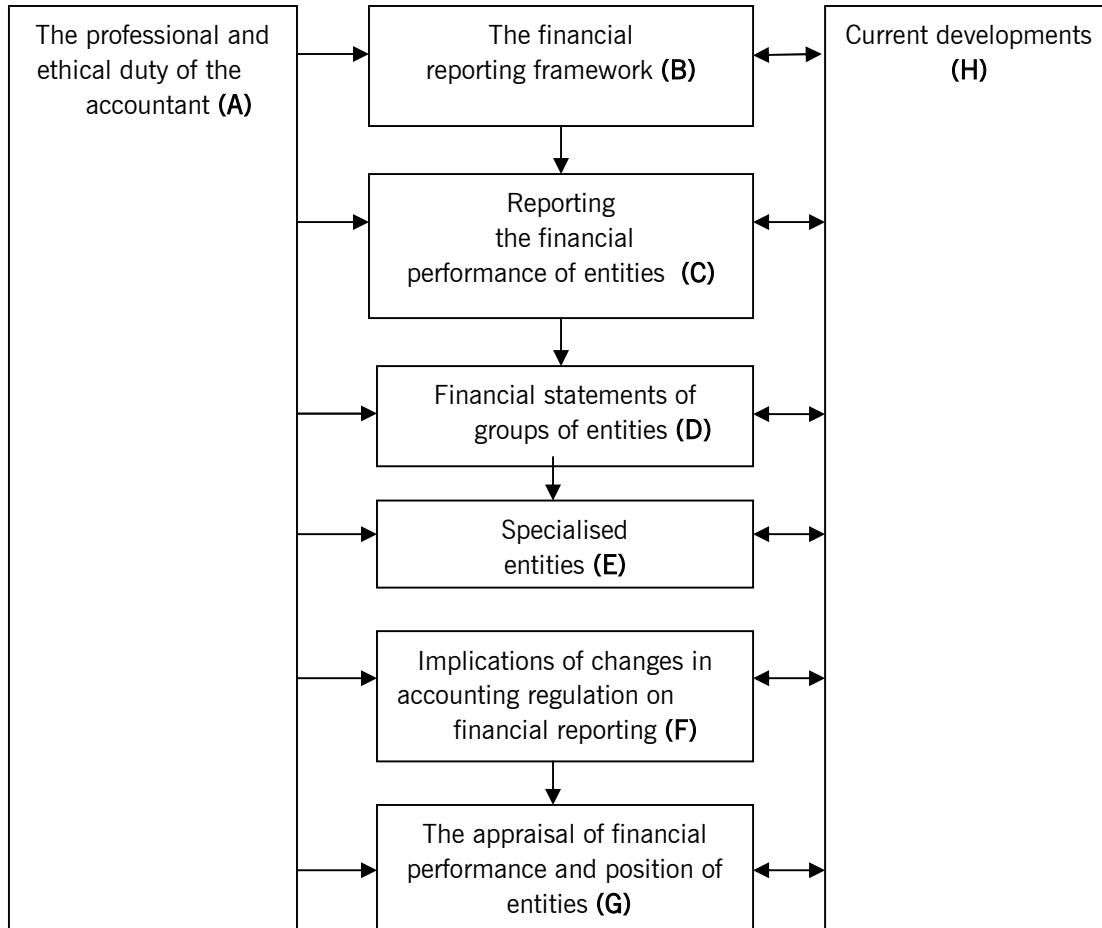

## RATIONALE

The syllabus for paper P2, *Corporate Reporting*, assumes knowledge acquired at the Fundamentals level including the core technical capabilities to prepare and analyse financial reports for single and combined entities.

The Paper P2 syllabus takes the subject into greater depth and contextualises the role of the accountant as a professional steward and adviser/analyst by initially exploring the wider professional duties and responsibilities of the accountant to the stakeholders of an organisation.

The syllabus examines the financial reporting framework within which the accountant operates and examines detailed financial reporting requirements for entities leading to the preparation of group financial reports in accordance with generally accepted accounting practice and relevant standards.

The syllabus then deals with the nature of reporting for specialised entities including not-for-profit and small and medium-sized enterprises.

The final sections of the syllabus explore – in more depth – the role of the accountant as financial analyst and adviser through the assessment of financial performance and position of entities, and the accountant's role in assessing and advising on the implications of accounting regulation on corporate reporting.

Finally, the syllabus covers the evaluation of current developments and their implications for financial reporting.

For the purpose of this exam, International Financial Reporting Standards (IFRS) are the main accounting standards examined in the preparation of financial information. The key differences between UK GAAP and International Financial Reporting Standards are looked at on a subject by subject basis.

## DETAILED SYLLABUS

### A The professional and ethical duty of the accountant

1. Professional behaviour and compliance with accounting standards
2. Ethical requirements of corporate reporting and the consequences of unethical behaviour
3. Social responsibility

### B The legal and financial reporting framework

1. The applications, strengths and weaknesses of an accounting framework
2. Critical evaluation of principles and practices
3. The legal requirements relating to the preparation of single entity financial reporting statements

### C Reporting the financial performance of entities

1. Performance reporting
2. Non-current assets
3. Financial instruments
4. Leases
5. Segment reporting
6. Employee benefits
7. Taxation
8. Provisions, contingencies and events after the reporting date
9. Related parties
10. Share-based payment
11. Reporting requirements of small and medium-sized entities (SMEs) including key differences between the requirements of the IFRS for SMEs and UK GAAP

### D Financial statements of groups of entities

1. Group accounting including cash flow statements
2. Continuing and discontinued interests
3. Changes in group structures
4. Foreign transactions and entities

### E Specialised entities and specialised transactions

1. Financial reporting in specialised, not-for-profit and public sector entities
2. Entity schemes of arrangement and reconstructions

### F Implications of changes in accounting regulation on financial reporting

1. The effect of changes in accounting standards on accounting systems
2. Proposed changes to accounting standards

### G The appraisal of financial performance and position of entities

1. The creation of suitable accounting policies
2. Analysis and interpretation of financial information and measurement of performance

### H Current developments

1. Environmental and social reporting
2. Convergence between national and international reporting standards
3. Current reporting issues

## APPROACH TO EXAMINING THE SYLLABUS

accounting standards will feature prominently in this section on initial introduction

The syllabus is assessed by a three-hour 15 minutes examination.

It examines professional competences within the corporate reporting environment.

Students will be examined on concepts, theories, and principles, and on their ability to question and comment on proposed accounting treatments.

Students should be capable of relating professional issues to relevant concepts and practical situations. The evaluation of alternative accounting practices and the identification and prioritisation of issues will be a key element of the paper. Professional and ethical judgement will need to be exercised, together with the integration of technical knowledge when addressing corporate reporting issues in a business context.

Global issues will be addressed via the current issues questions on the paper. Students will be required to adopt either a stakeholder or an external focus in answering questions and to demonstrate personal skills such as problem solving, dealing with information and decision making.

The paper also deals with specific professional knowledge appropriate to the preparation and presentation of consolidated and other financial statements from accounting data to conform with accounting standards.

The paper will comprise two sections.

Section A Compulsory question    50 marks

Section B 2 from 3 questions of  
25 marks each                    50 marks  
   100 marks

Section A will consist of one scenario-based question worth 50 marks. It will deal with the preparation of consolidated financial statements including group cash flow statements and with issues in financial reporting.

Students will be required to answer two out of three questions in Section B, which will normally comprise two questions which will be scenario or case-study based and one essay question which may have some computational element. Section B could deal with any aspects of the syllabus. New



# Study Guide

## A THE PROFESSIONAL AND ETHICAL DUTIES OF THE ACCOUNTANT

### 1. Professional behaviour and compliance with accounting standards

- a) Appraise and discuss the ethical and professional issues in advising on corporate reporting.<sup>[3]</sup>
- b) Assess the relevance and importance of ethical and professional issues in complying with accounting standards.<sup>[3]</sup>

### 2. Ethical requirements of corporate reporting and the consequences of unethical behaviour

- a) Appraise the potential ethical implications of professional and managerial decisions in the preparation of corporate reports.<sup>[3]</sup>
- b) Assess the consequences of not upholding ethical principles in the preparation of corporate reports.<sup>[3]</sup>

### 3. Social Responsibility

- a) Discuss the increased demand for transparency in corporate reports, and the emergence of non-financial reporting standards.<sup>[3]</sup>
- b) Discuss the progress towards a framework for integrated reporting.<sup>[3]</sup>

## B THE FINANCIAL REPORTING FRAMEWORK

### 1. The applications, strengths and weaknesses of an accounting framework

- a) Evaluate the “valuation models adopted by standard setters.”<sup>[3]</sup>
- b) Discuss the use of an accounting framework in underpinning the production of accounting standards.<sup>[3]</sup>
- c) Assess the success of such a framework in introducing rigorous and consistent accounting standards.<sup>[3]</sup>

### 2. Critical evaluation of principles and practices

- a) Identify the relationship between accounting theory and practice.<sup>[2]</sup>
- b) Critically evaluate accounting principles and practices used in corporate reporting.<sup>[3]</sup>

### 3. Legal requirements relating to the preparation of single entity financial statements

- a) Recognise and apply the laws, regulations, accounting standards and other requirements to the preparation of statutory financial statements of an entity including the circumstances where an entity is required to prepare and present statutory financial statements.<sup>[2]</sup>

## C REPORTING THE FINANCIAL PERFORMANCE OF ENTITIES

### 1. Performance reporting

- a) Prepare reports relating to corporate performance for external stakeholders.<sup>[3]</sup>
- b) Discuss and apply the criteria that must be met before an entity can apply the revenue recognition model to a contract.<sup>[3]</sup>
- c) Discuss and apply the five-step model which relates to revenue earned from a contract with a customer.<sup>[3]</sup>

### 2. Non-current assets

- a) Apply and discuss the timing of the recognition of non-current assets and the determination of their carrying amounts including impairments and revaluations.<sup>[3]</sup>
- b) Apply and discuss the treatment of non-current assets held for sale.<sup>[3]</sup>
- c) Apply and discuss the accounting treatment of investment properties including classification, recognition and measurement issues.<sup>[3]</sup>
- d) Apply and discuss the accounting treatment of intangible assets including the criteria for recognition and measurement subsequent to acquisition and classification.<sup>[3]</sup>

### 3. Financial Instruments

- a) Apply and discuss the recognition and de-recognition of financial assets and financial liabilities.<sup>[2]</sup>
- b) Apply and discuss the classification of financial assets and financial liabilities and their measurement.<sup>[2]</sup>
- c) Apply and discuss the treatment of gains and losses arising on financial assets and financial liabilities.<sup>[2]</sup>
- d) Apply and discuss the treatment of the expected loss impairment model.<sup>[2]</sup>
- e) Account for derivative financial instruments, and simple embedded derivatives.<sup>[2]</sup>
- f) Outline the principles of hedge accounting and account for fair value hedges and cash flow hedges including hedge effectiveness.<sup>[2]</sup>

### 4. Leases

- a) Discuss and apply the accounting treatment for leases by lessees including the measurement of the right of use asset and liability
- b. Discuss and apply the accounting for leases by lessors
- c Discuss and apply the circumstances where there may be re-measurement of the lease liability
- d. Discuss and apply the reasons behind the separation of the components of a lease contract into lease and non-lease elements
- e Discuss the recognition exemptions under the current leasing standard
  
- f) Account for and discuss sale and leaseback transactions.<sup>[3]</sup>

### 5. Segment Reporting

- a) Determine the nature and extent of reportable segments.<sup>[3]</sup>
- b) Specify and discuss the nature of segment information to be disclosed.<sup>[3]</sup>

### 6. Employee Benefits

- a) Apply and discuss the accounting treatment of short term and long term benefits and defined contribution and defined benefit plans .<sup>[3]</sup>
- b) Account for gains and losses on settlements and curtailments.<sup>[2]</sup>
- c) Account for the “Asset Ceiling” test and the reporting of actuarial gains and losses.<sup>[2]</sup>

### 7. Taxation

- a) Apply and discuss the recognition and measurement of deferred tax liabilities and deferred tax assets.<sup>[3]</sup>
- b) Determine the recognition of tax expense or income and its inclusion in the financial statements.<sup>[3]</sup>

### 8. Provisions, contingencies and events after the reporting date

- a) Apply and discuss the recognition, de-recognition and measurement of provisions, contingent liabilities and contingent assets including environmental provisions and restructuring provisions.<sup>[3]</sup>
- b) Apply and discuss the accounting for events after the reporting date.<sup>[3]</sup>
- c) Determine and report going concern issues arising after the reporting date.<sup>[3]</sup>

### 9. Related parties

- a) Determine the parties considered to be related to an entity.<sup>[3]</sup>
- b) Identify the implications of related party relationships and the need for disclosure.<sup>[3]</sup>

### 10. Share based payment

- a) Apply and discuss the recognition and measurement criteria for share-based payment transactions.<sup>[3]</sup>

- b) Account for modifications, cancellations and settlements of share based payment transactions.<sup>[2]</sup>

## 11. Reporting requirements of small and medium-sized entities (SMEs)

- a) Discuss the accounting treatments not allowable under the IFRS for SME's including the revaluation model for certain assets ,<sup>[3]</sup>
- b) Discuss and apply the simplifications introduced by the IFRS for SME's including accounting for goodwill and intangible assets, financial instruments, defined benefit schemes, exchange differences and associates and joint ventures.<sup>[3]</sup>
- c) Discuss the key differences between the IFRS for SMEs and UK GAAP.<sup>[2]</sup>

## D FINANCIAL STATEMENTS OF GROUPS OF ENTITIES

### 1. Group accounting including cash flow statements

- a) Apply the method of accounting for business combinations including complex group structures.<sup>[3]</sup>
- b) Apply the principles in determining the cost of a business combination.<sup>[3]</sup>
- c) Apply the recognition and measurement criteria for identifiable acquired assets and liabilities and goodwill including step acquisitions.<sup>[3]</sup>
- d) Apply and discuss the criteria used to identify a subsidiary and an associate.<sup>[3]</sup>
- e) Determine and apply appropriate procedures to be used in preparing group financial statements.<sup>[3]</sup>
- f) Identify and outline (using relevant legislation, accounting standards and other applicable regulation):
  - the circumstances in which a group is required to prepare consolidated financial statements.<sup>[2]</sup>
  - the circumstances when a group may claim and exemption from the preparation of

- consolidated financial statements.<sup>[2]</sup>
- why directors may not wish to consolidate a subsidiary and where this is permitted.<sup>[2]</sup>

- g) Apply the equity method of accounting for associates.<sup>[3]</sup>
- h) Outline and apply the key definitions and accounting methods which relate to interests in joint arrangements.<sup>[3]</sup>
- i) Prepare and discuss group cash flow statements.<sup>[3]</sup>

### 2. Continuing and discontinued interests

- a) Prepare group financial statements where activities have been discontinued, or have been acquired or disposed of in the period.<sup>[3]</sup>
- b) Apply and discuss the treatment of a subsidiary which has been acquired exclusively with a view to subsequent disposal.<sup>[3]</sup>

### 3. Changes in group structures

- a) Discuss the reasons behind a group reorganisation.<sup>[3]</sup>
- b) Evaluate and assess the principal terms of a proposed group reorganisation.<sup>[3]</sup>

### 4. Foreign transactions and entities

- a) Outline and apply the translation of foreign currency amounts and transactions into the functional currency and the presentational currency.<sup>[3]</sup>
- b) Account for the consolidation of foreign operations and their disposal.<sup>[2]</sup>

## E SPECIALISED ENTITIES AND SPECIALISED TRANSACTIONS

### 1. Financial reporting in specialised, not-for-profit and public sector entities

- a) Apply knowledge from the syllabus to straightforward transactions and events arising in specialised, not-for-profit, and public sector entities.<sup>[3]</sup>

## **2. Entity schemes of arrangement and reconstructions**

- a) Identify when an entity may no longer be viewed as a going concern or uncertainty exists surrounding the going concern status.<sup>[2]</sup>
- b) Identify and outline the circumstances in which a scheme of arrangement or reconstruction would be an appropriate alternative to a company liquidation.<sup>[2]</sup>
- c) Outline the appropriate accounting treatment relating to schemes of arrangement and reconstructions.<sup>[2]</sup>

## **F IMPLICATIONS OF CHANGES IN ACCOUNTING REGULATION ON FINANCIAL REPORTING**

### **1. The effect of changes in accounting standards on accounting systems**

- a) Apply and discuss the accounting implications of the first time adoption of a body of new accounting standards.<sup>[3]</sup>

### **2. Proposed changes to accounting standards**

- a) Identify issues and deficiencies which have led to a proposed change to an accounting standard.<sup>[2]</sup>

## **G THE APPRAISAL OF FINANCIAL PERFORMANCE AND POSITION OF ENTITIES**

### **1. The creation of suitable accounting policies**

- a) Develop accounting policies for an entity which meet the entity's reporting requirements.<sup>[3]</sup>
- b) Identify accounting treatments adopted in financial statements and assess their suitability and acceptability.<sup>[3]</sup>

### **2. Analysis and interpretation of financial information and measurement of performance**

- a) Select and calculate relevant indicators of financial and non-financial performance.<sup>[3]</sup>
- b) Identify and evaluate significant features and issues in financial statements.<sup>[3]</sup>

- c) Highlight inconsistencies in financial information through analysis and application of knowledge.<sup>[3]</sup>
- d) Make inferences from the analysis of information taking into account the limitation of the information, the analytical methods used and the business environment in which the entity operates.<sup>[3]</sup>

## **H CURRENT DEVELOPMENTS**

### **1. Environmental and social reporting**

- a) Appraise the impact of environmental, social, and ethical factors on performance measurement.<sup>[3]</sup>
- b) Evaluate current reporting requirements in the area including the development of integrated reporting.<sup>[3]</sup>
- c) Discuss why entities might include disclosures relating to the environment and society.<sup>[3]</sup>

### **2. Convergence between national and international reporting standards**

- a) Evaluate the implications of worldwide convergence with International Financial Reporting Standards.<sup>[3]</sup>
- b) Discuss the influence of national regulators on international financial reporting.<sup>[2]</sup>

### **3. Current reporting issues**

- a) Discuss current issues in corporate reporting, including:
  - i. recent IFRSs
  - ii. practice and regulatory issues
  - iii. proposed changes to IFRS
  - iv. problems with extant standards<sup>[3]</sup>

**NOTE OF SIGNIFICANT CHANGES TO STUDY  
GUIDE PAPER P2 UK**

**RATIONALE FOR CHANGES**

ACCA periodically reviews its qualification syllabuses so that they fully meet the needs of stakeholders such as employers, students, regulatory and advisory bodies and learning providers

The main areas that have been added to the syllabus are shown in Table 1 below:

Table 1 - Additions to P2 (UK)

Section and subject area	Syllabus content
B4 Leases	New learning outcomes (a)-(e) have been inserted to reflect the issue of IFRS 16 Leases. There has been no change to learning outcome B4(f) [formally B4 (b)]

The main areas that have been deleted from the syllabus are shown in Table 2 below:

Table 2 – Deletions from P2 (UK)

Section and subject area	Syllabus content
B4 Leases	Apply and discuss the classification of leases and accounting for leases by lessors and lessees.

There have been no other amends to the P2 (UK) syllabus

The syllabus must be read in conjunction with the Examinable Documents list.